



Your **definitive** source
for quality pre-owned
equipment.

Artisan Technology Group

(217) 352-9330 | sales@artisanTG.com | artisanTG.com

Full-service, independent repair center

with experienced engineers and technicians on staff.

We buy your excess, underutilized, and idle equipment

along with credit for buybacks and trade-ins.

Custom engineering

so your equipment works exactly as you specify.

- Critical and expedited services
- In stock / Ready-to-ship
- Leasing / Rentals / Demos
- ITAR-certified secure asset solutions

Expert team | Trust guarantee | 100% satisfaction

All trademarks, brand names, and brands appearing herein are the property of their respective owners.

Find the *Keysight / Agilent 81663A* at our website: **Click *HERE***

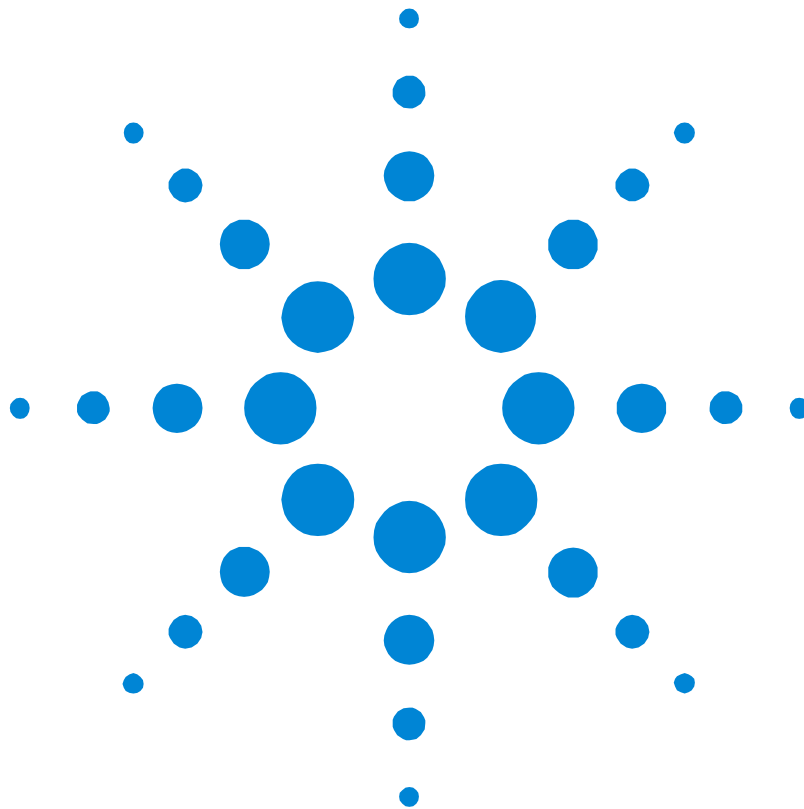

Agilent 81662A and Agilent 81663A
DFB Laser Source Modules

User's Guide

Notices

This document contains proprietary information that is protected by copyright. All rights are reserved.

No part of this document may be photocopied, reproduced, or translated to another language without the prior written consent of Agilent Technologies Deutschland GmbH.

© Copyright 2001 by:
Agilent Technologies Deutschland GmbH
Herrenberger Str. 130
71034 Böblingen
Germany

Subject Matter

The information in this document is subject to change without notice.

Agilent Technologies makes no warranty of any kind with regard to this printed material, including, but not limited to, the implied warranties of merchantability and fitness for a particular purpose.

Agilent Technologies shall not be liable for errors contained herein or for incidental or consequential damages in connection with the furnishing, performance, or use of this material.

Printing History

New editions are complete revisions of the guide reflecting alterations in the functionality of the instrument. Updates are occasionally made to the guide between editions. The date on the title page changes when an updated guide is published. To find out the current revision of the guide, or to purchase an updated guide, contact your Agilent Technologies representative.

Warranty

This Agilent Technologies instrument product is warranted against defects in material and workmanship for a period of one year from date of shipment. During the warranty period, Agilent will, at its option, either repair or replace products that prove to be defective.

For warranty service or repair, this product must be returned to a service facility designated by Agilent. Buyer shall prepay shipping charges to Agilent and Agilent shall pay shipping charges to return the product to Buyer. However, Buyer shall pay all shipping charges, duties, and taxes for products returned to Agilent from another country.

Agilent warrants that its software and firmware designated by Agilent for use with an instrument will execute its programming instructions when properly installed on that instrument. Agilent does not warrant that the operation of the instrument, software, or firmware will be uninterrupted or error free.

Limitation of Warranty

The foregoing warranty shall not apply to defects resulting from improper or inadequate maintenance by Buyer, Buyer-supplied software or interfacing, unauthorized modification or misuse, operation outside of the environmental specifications for the product, or improper site preparation or maintenance.

No other warranty is expressed or implied. Agilent Technologies specifically disclaims the implied warranties of Merchantability and Fitness for a Particular Purpose.

Exclusive Remedies

The remedies provided herein are Buyer's sole and exclusive remedies. Agilent Technologies shall not be liable for any direct, indirect, special, incidental, or consequential damages whether based on contract, tort, or any other legal theory.

Assistance

Product maintenance agreements and other customer assistance agreements are available for Agilent Technologies products. For any assistance contact your nearest Agilent Technologies Sales and Service Office.

Certification

Agilent Technologies Company certifies that this product met its published specifications at the time of shipment from the factory.

Agilent Technologies further certifies that its calibration measurements are traceable to the United States National Institute of Standards and Technology, NIST (formerly the United States National Bureau of Standards, NBS) to the extent allowed by the Institutes' calibration facility, and to the calibration facilities of other International Standards Organization members.

ISO 9001 Certification

Produced to ISO 9001 international quality system standard as part of our objective of continually increasing customer satisfaction through improved process control.

Fifth Edition 81661-90A15 February 2002

First Edition:
81661-90014: E0600
June 2000

Second Edition:
81661-90014: E1000:
October 2000

Third Edition:
81661-90014: E0101
January 2001

Fourth Edition:
81661-90014: E0801
August 2001

Fifth Edition:
81661-90A15
February 2002

Safety Considerations

The following general safety precautions must be observed during all phases of operation, service, and repair of this instrument. Failure to comply with these precautions or with specific warnings elsewhere in this manual violates safety standards of design, manufacture, and intended use of the instrument. Agilent Technologies assumes no liability for the customer's failure to comply with these requirements.

Before operation, review the instrument and manual, including the red safety page, for safety markings and instructions. You must follow these to ensure safe operation and to maintain the instrument in safe condition.

WARNING

The WARNING sign denotes a hazard. It calls attention to a procedure, practice or the like, which, if not correctly performed or adhered to, could result in injury or loss of life. Do not proceed beyond a WARNING sign until the indicated conditions are fully understood and met.



Safety Symbols

The apparatus will be marked with this symbol when it is necessary for the user to refer to the instruction manual in order to protect the apparatus against damage.



Hazardous laser radiation.

Initial Inspection

Inspect the shipping container for damage. If there is damage to the container or cushioning, keep them until you have checked the contents of the shipment for completeness and verified the instrument both mechanically and electrically.

The Performance Tests give procedures for checking the operation of the instrument. If the contents are incomplete, mechanical damage or defect is apparent, or if an instrument does not pass the operator's checks, notify the nearest Agilent Technologies Sales/Service Office.

WARNING

To avoid hazardous electrical shock, do not perform electrical tests when there are signs of shipping damage to any portion of the outer enclosure (covers, panels, etc.).

WARNING

You *MUST* return instruments with malfunctioning laser modules to an Agilent Technologies Service Center for repair and calibration.

Line Power Requirements

The Agilent 81662A and Agilent 81663A DFB Laser Source Modules operate when installed in the Agilent 8163A Lightwave Multimeter, Agilent 8164A Lightwave Measurement System, or Agilent 8166A Lightwave Multichannel System.

Operating Environment

The safety information in the Agilent 8163A Lightwave Multimeter, Agilent 8164A Lightwave Measurement System, & Agilent 8166A Lightwave Multichannel System User's Guide summarizes the operating ranges for the Agilent 81662A and Agilent 81663A DFB Laser Source Modules. In order for these modules to meet specifications, the operating environment must be within the limits specified for the mainframe.

Storage and Shipment

These modules can be stored or shipped at temperatures between -40°C and $+70^{\circ}\text{C}$. Protect the module from temperature extremes that may cause condensation within it.

Initial Safety Information for DFB Laser Source Modules

The laser sources specified by this user guide are classified according to IEC 60825-1 (2001)

The laser sources comply with 21 CFR 1040.10 except for deviations pursuant to Laser Notice No. 50, dated 2001-July-26

Table 1 DFB Laser Source Modules Safety Information

	Agilent 81662A	Agilent 81663A
<i>Laser type</i>	CW DFB Laser with built-in isolator	CW DFB Laser with built-in isolator
<i>Wavelength range</i>	1500 - 1650 NM see display	1500 - 1650 NM see display
<i>Max. CW output power*</i>	<15 mW	<28 mW
<i>Beam waist diameter</i>	9 μ m	9 μ m
<i>Numerical aperture</i>	0.1	0.1
<i>Laser Class according to IEC 60825-1 (2001)- International</i>	1M	1M
<i>Max. permissible CW output power</i>	163 mW	163 mW
* Max. CW output power is defined as the highest possible optical power that the laser source can produce at its output connector		

Laser Safety Labels

Laser class 1M label

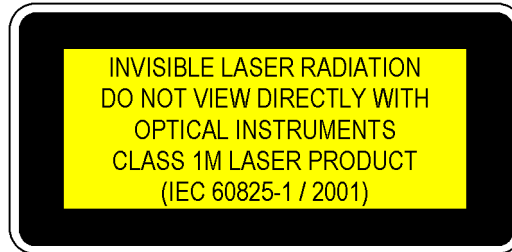

Figure 1 Class 1M Safety Label - Agilent 81662A/3A

A sheet of laser safety labels is included with the laser module as required. In order to meet the requirements of IEC 60825-1 we recommend that you stick the laser safety labels, in your language, onto a suitable location on the outside of the instrument where they are clearly visible to anyone using the instrument

WARNING

Please pay attention to the following laser safety warnings:

- Under no circumstances look into the end of an optical cable attached to the optical output when the device is operational. The laser radiation can seriously damage your eyesight.
- Do not enable the laser when there is no fiber attached to the optical output connector.
- The laser is enabled by pressing the gray button close to the optical output connector on the front panel of the module. The laser is on when the green LED on the front panel of the instrument is lit.
- The use of the instruments with this product will increase the hazard to your eyes.
- The laser module has built-in safety circuitry which will disable the optical output in the case of a fault condition.
- Refer servicing *only* to qualified and authorized personnel.

Table of Contents

Safety Considerations	3
Safety Symbols	3
Initial Inspection	4
Line Power Requirements	4
Operating Environment	4
Storage and Shipment	4
Initial Safety Information for DFB Laser Source Modules	5
Laser Safety Labels	6
Getting Started with DFB Laser Sources	13
Getting Started with DFB Laser Source Modules	15
What is a DFB Laser Source Module?	15
A Description of the Front Panel	15
How to Enable/Disable Laser Output	15
Optical Output	16
Polarization Maintaining Fiber	16
Angled Contact Connectors	16
Operation Note	17
Maintaining Wavelength Accuracy Below Maximum Power	17
Accessories	19
Recommended Connector Interfaces	21
ITU Channel Options	22
Specifications	25
Definition of Terms	27
Wavelength tuning range	27
Wavelength display resolution	27
Wavelength repeatability	27
Wavelength stability	28
Max. output power	28
Power CW stability	28

Sidemode suppression ratio (SMSR)	28
Polarization extinction ratio (PER)	29
Coherence control	29
Modulation, digital	29
ON- switching with fast output power stabilization	29
Tuning Speed	29
DFB Source Module Specifications	31
Supplementary Performance Characteristics	32
Performance Tests	33
<hr/>	
Equipment Required	35
Test Record	35
Test Failure	35
Instrument Specification	36
Performance Test Instructions	36
All Wavelength Tests	37
General Settings for Burleigh WA-1500 Wavelength Meter	37
Wavelength Repeatability Test	37
Wavelength Stability Test	39
Cleaning Information	45
<hr/>	
Safety Precautions	47
Why is it important to clean optical devices?	47
What do I need for proper cleaning?	48
Standard Cleaning Equipment	48
Dust and shutter caps	48
Isopropyl alcohol	49
Cotton swabs	49
Soft tissues	50
Pipe cleaner	50
Compressed air	50
Additional Cleaning Equipment	51
Microscope with a magnification range about 50X up to 300X	51
Ultrasonic bath	51
Warm water and liquid soap	52
Premoistened cleaning wipes	52
Polymer film	52
Infrared Sensor Card	52

Preserving Connectors	53
Cleaning Instrument Housings	53
Which Cleaning Procedure should I use ?	54
How to clean connectors	54
How to clean connector adapters	55
How to clean connector interfaces	56
How to clean bare fiber adapters	57
How to clean lenses	58
How to clean instruments with a fixed connector interface	58
How to clean instruments with an optical glass plate	59
How to clean instruments with a physical contact interface	59
How to clean instruments with a recessed lens interface	60
How to clean optical devices which are sensitive to mechanical stress and pressure	61
How to clean metal filters or attenuator gratings	62
Additional Cleaning Information	63
How to clean bare fiber ends	63
How to clean large area lenses and mirrors	63
Other Cleaning Hints	65



Getting Started with DFB Laser Sources

This chapter introduces the features of the Agilent 81662A and Agilent 81663A DFB Laser Source Modules.

Getting Started with DFB Laser Source Modules

What is a DFB Laser Source Module?

A distributed feedback (DFB) laser is a highly-coherent laser source that emits radiation in a narrow spectral width. The Agilent Technologies range of DFB laser source modules may be tuned within a specific wavelength range, the current wavelength is displayed on the user interface of your mainframe. The wavelength of the ITU channel your module supports is displayed on the front panel, see Figure 3.

A Description of the Front Panel

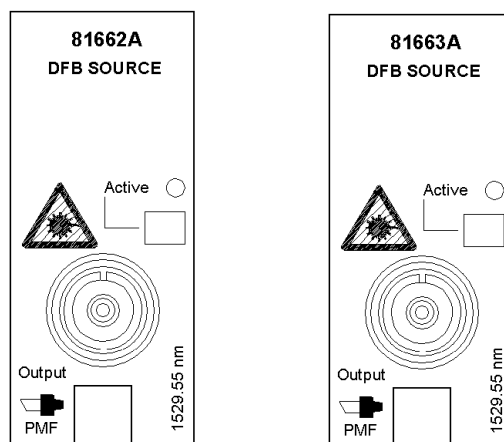

Figure 3 Front Panel of DFB Laser Source Modules

To insert these modules into your mainframe see your mainframe's User's Guide.

How to Enable/Disable Laser Output

This indicates whether the module is emitting radiation. If the State parameter is On, the green LED on the front panel of the module is lit indicating the laser is active. If the State parameter is Off, green LED on the front panel of the module is unlit indicating the laser is inactive. You can switch the module by pressing the Active button on the front panel of the module.

Optical Output

Polarization Maintaining Fiber

The Agilent 81662A and Agilent 81663A DFB Laser Source modules are equipped with a polarization maintaining fiber (PMF) as standard, the PMF is aligned to maintain the state of polarization.

The fiber is of Panda type, with TE mode in the slow axis in line with the connector key. A well defined state of polarization ensures constant measurement conditions.

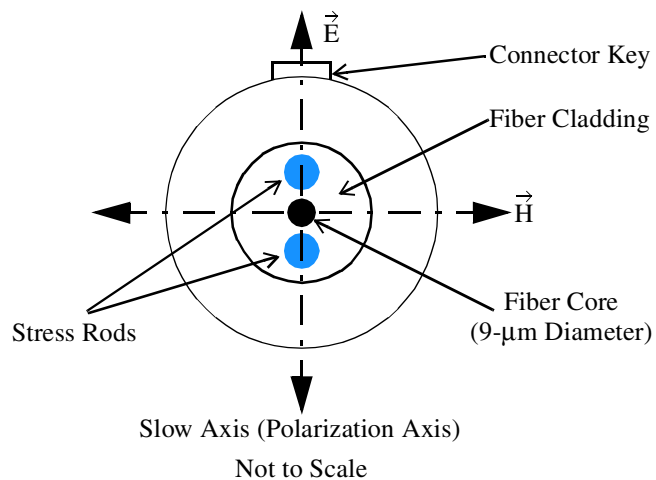

Figure 4 PMF Output Connector

Angled Contact Connectors

The Agilent 81662A and Agilent 81663A DFB Laser Source modules are equipped with an angled contact optical output connector as standard.

Angled contact connectors help you to control return loss. With angled fiber endfaces, reflected light tends to reflect into the cladding, reducing the amount of light that reflects back to the source.

CAUTION

If the contact connector on your instrument is angled, you can only use cables with angled connectors with the instrument.

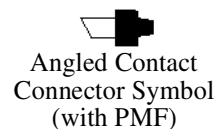

Figure 5 Angled Contact Connector Symbols

Figure 5 shows the symbols that tell you whether the contact connector of your Tunable Laser module is angled or straight. The angled contact connector symbol for an optical output equipped with a PMF is colored green.

Operation Note

Maintaining Wavelength Accuracy Below Maximum Power

The wavelength accuracy of your DFB Laser Source module is optimized when you set power to the maximum available for your module. As you reduce power, the drive current through the laser diode changes; this can mean that the actual output wavelength may differ from the wavelength displayed on the user interface of your mainframe.

To ensure wavelength accuracy at less than maximum power you should perform the steps listed below. You will need to use a wavelength meter, we recommend the HP 86120C Multi-Wavelength Meter.

- 1 Set up your equipment as displayed in Figure 6.

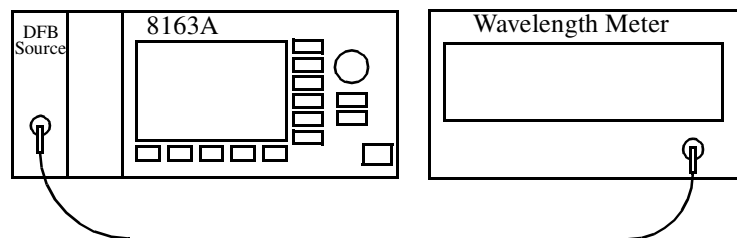

Figure 6 Wavelength Accuracy Setup

1. On the user interface of your Agilent 8163A Lightwave Multimeter, move to the DFB source module channel and perform the following steps:
 - a Move to [P], and press *Enter*.
 - b Set the power value to the maximum power for the module. The maximum power for the 81662A is 10 dBm; the maximum power for the 81663A is 13 dBm.
 - c Move to [λ], and press *Enter*.

- d Set the wavelength to the value you require.
 - e Enable the laser by pressing the button on the front panel of the module.
- 2 Allow your wavelength meter to settle to a stable wavelength value. Check the displayed value against the value displayed on the user interface of your 8163A Lightwave Multimeter.
- 3 On the user interface of your 8163A Lightwave Multimeter, perform the following steps:
 - a Move to [P], and press *Enter*.
 - b Reduce the power value below the maximum power for the module. The maximum power for the 81662A is 10 dBm; the maximum power for the 81663A is 13 dBm.
- 4 Allow your wavelength meter to settle to a stable wavelength value. If the displayed value is not accurate enough for your application, on the user interface of your 8163A Lightwave Multimeter, perform the following steps:
 - a Move to [λ], and press *Enter*.
 - b Adjust the wavelength value until the wavelength meter displays the wavelength you require. Allow time for the wavelength meter to settle.

NOTE The DFB Laser Source channel will display a wavelength value that differs from the value displayed by the wavelength meter. The wavelength meter displays the correct value.



Accessories

Agilent 81662A and Agilent 81663A DFB Laser Source Modules are available in various configurations for the best possible match to the most common applications.

This chapter provides information on the available options and accessories.

Recommended Connector Interfaces

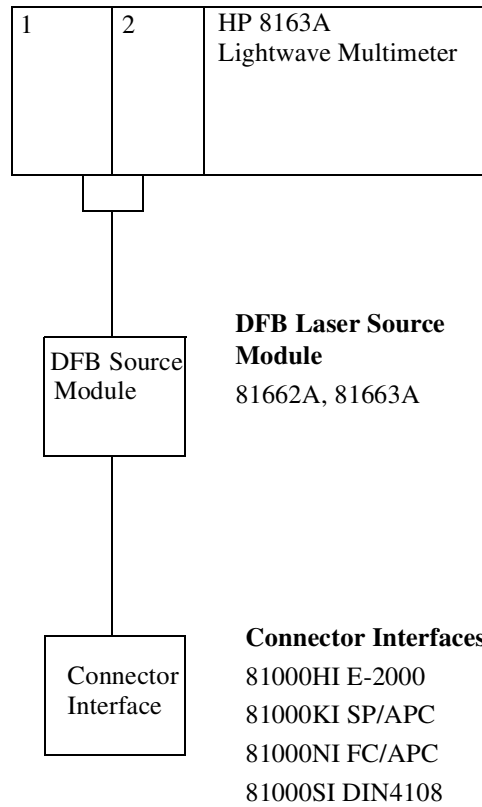

Figure 7 Recommended Connector Interfaces

ITU Channel Options

Agilent 81662A and 81663A Option Number	ITU Frequency [THz]	Center Wavelength [nm]
#309	196.00	1,529.55
#311	195.90	1,530.33
#313	195.80	1,531.12
#315	195.70	1,531.90
#317	195.60	1,532.68
#319	195.50	1,533.47
#321	195.40	1,534.25
#323	195.30	1,535.04
#325	195.20	1,535.82
#327	195.10	1,536.61
#329	195.00	1,537.40
#331	194.90	1,538.19
#333	194.80	1,538.98
#335	194.70	1,539.77
#337	194.60	1,540.56
#339	194.50	1,541.35
#341	194.40	1,542.14
#343	194.30	1,542.94
#345	194.20	1,543.73
#347	194.10	1,544.53
#349	194.00	1,545.32
#351	193.90	1,546.12
#353	193.80	1,546.92
#355	193.70	1,547.72
#357	193.60	1,548.51
#359	193.50	1,549.32
#361	193.40	1,550.12
#363	193.30	1,550.92
#365	193.20	1,551.72
#367	193.10	1,552.52
#369	193.00	1,553.33
#371	192.90	1,554.13
#373	192.80	1,554.94
#375	192.70	1,555.75
#377	192.60	1,556.55

Agilent 81662A and 81663A Option Number	ITU Frequency [THz]	Center Wavelength [nm]
#379	192.50	1,557.36
#381	192.40	1,558.17
#383	192.30	1,558.98
#385	192.20	1,559.79
#387	192.10	1,560.61
#389	192.00	1,561.42
#391	191.90	1,562.23
#393	191.80	1,563.05
#395	191.70	1,563.86
#397	191.60	1,564.68
#399	191.50	1,565.50
#401	191.40	1,566.31
#403	191.30	1,567.13
#405	191.20	1,567.95
#407	191.10	1,568.77
#409	191.00	1,569.59
#411	190.90	1,570.42
#413	190.80	1,571.24
#415	190.70	1,572.06
#417	160.60	1,572.89
#419	160.50	1,573.71
#421	190.40	1,574.54
#423	190.30	1,575.37
#425	190.20	1,576.20
#427	190.10	1,577.03
#429	190.00	1,577.86
#431	189.90	1,578.69
#433	189.80	1,579.52
#435	189.70	1,580.35
#437	189.60	1,581.18
#439	189.50	1,582.02
#441	189.40	1,582.85
#443	189.30	1,583.69
#445	189.20	1,584.53
#447	189.10	1,585.36
#449	189.00	1,586.20
#451	188.90	1,587.04
#453	188.80	1,587.88
#455	188.70	1,588.73

Agilent 81662A and 81663A Option Number	ITU Frequency [THz]	Center Wavelength [nm]
#457	188.60	1,589.57
#459	188.50	1,590.41
#461	188.40	1,591.26
#463	188.30	1,592.10
#465	188.20	1,592.95
#467	188.10	1,593.79
#469	188.00	1,594.64
#471	187.90	1,595.49
#473	187.80	1,596.34
#475	187.70	1,597.19
#477	187.60	1,598.04
#479	187.50	1,598.89
#481	187.40	1,599.75
#483	187.30	1,600.60
#485	187.20	1,601.46
#487	187.10	1,602.31
#489	187.00	1,603.17
#491	186.90	1,604.03
#493	186.80	1,604.88
#495	186.70	1,605.74
#497	186.60	1,606.60
#499	186.50	1,607.47
#501	186.40	1,608.33
#503	186.30	1,609.19
#505	186.20	1,610.06



Specifications

Agilent 81662A and Agilent 81663A DFB Laser Source Modules are produced to the ISO 9001 international quality system standard as part of Agilent's commitment to continually increasing customer satisfaction through improved quality control.

Specifications describe the module's warranted performance. Supplementary performance characteristics describe the module's non-warranted typical performance.

Because of the modular nature of the instrument, these performance specifications apply to these modules rather than the mainframe unit.

Definition of Terms

This section defines terms that are used both in this chapter and “Performance Tests” on page 33.

Generally, all specifications apply for the given environmental conditions and after warmup time.

Measurement principles are indicated. Alternative measurement principles of equal value are also acceptable.

Wavelength tuning range

The range of wavelengths for which the specifications apply, where the relevant ITU grid wavelength is defined as the center of the tuning range.

Conditions: at specified conditions and coherence control off.

Measurement: with wavelength meter.

Wavelength display resolution

The smallest possible displayed wavelength increment / decrement.

Wavelength repeatability

The random uncertainty in reproducing the wavelength after detuning and re-setting the wavelength. The wavelength repeatability is \pm half the span between the maximum and the minimum value of all measured wavelengths.

Conditions: uninterrupted DFB SOURCE MODULE output power, constant power level, coherence control off, controlled environment as specified.

Measurement: with wavelength meter. Averaging time given by wavelength meter, ≥ 1 s.

NOTE The long-term wavelength repeatability can be obtained by taking the wavelength repeatability and wavelength stability into account.

Wavelength stability

The change of wavelength during given time span, expressed as \pm half the span between the maximum and the minimum of all measured wavelengths.

Conditions: uninterrupted DFB SOURCE MODULE output power, constant wavelength and power level settings, coherence control off, controlled environment and time span as specified.

Measurement: with wavelength meter. Averaging time given by wavelength meter ≥ 1 s.

Max. output power

The highest optical power obtainable at the end of a single-mode fiber patchcord.

Conditions: at ITU-T center wavelength.

Measurement: with power meter at the end of a single-mode fiber patchcord.

Power CW stability

The change of the power level during given time span, expressed as \pm half the span (in dB) between the highest and lowest measured power.

Conditions: uninterrupted DFB SOURCE MODULE output power, constant wavelength and power level settings, controlled environment and time span as specified.

Measurement: with optical power meter.

Sidemode suppression ratio (SMSR)

The ratio of the optical power of the main mode to the optical power of the highest sidemode within the wavelength range from 1529.05 nm to 1617.00 nm (C- and L- Band of the ITU-Grid), expressed in dB.

Conditions: at a specified output power and wavelength, coherence control off.

Measurement: with the optical spectrum analyzer HP70950B, resolution bandwidth 0.1 nm.

Polarization extinction ratio (PER)

The ratio of optical power in the slow axis of the polarization-maintaining fiber to optical power in the fast axis.

Measurement: with a polarization analyzer by mechanically stressing the Panda fiber.

Coherence control

Linewidth broadening of optical signal by internal laser modulation.

Modulation, digital

Output signal is modulated with 50% duty cycle by internal on / off switching of the laser current. Switching frequencies as specified.

ON- switching with fast output power stabilization

When the laser is switched on after the specified warm-up time the output power will settle within the specified time to comply with the power stability specifications.

Tuning Speed

Maximum time required to change the wavelength of the optical signal between the extreme ends of the specified wavelength tuning range.

DFB Source Module Specifications

	Agilent 81662A	Agilent 81663A
	For Peak Wavelengths see options	
Type	CW DFB Laser, with built-in isolator	
Wavelength [1] [2]	ITU Grid (100 GHz)	ITU Grid (100 GHz)
Tuning Range	typ. > ±500pm	typ. > ±850pm
Display Resolution	10pm	10pm
Repeatability [5]	± 3pm (typ. ± 1pm)	± 5pm (typ. ± 2pm)
Stability (15min.) [4] [5]	± 3pm (typ. ± 1pm)	± 5pm (typ. ± 2pm)
Stability (24h) [4] [5]	typ. ± 5pm	typ. ± 5pm
Fiber type	Panda PMF 9 / 125 μm	
Output Connector [7]	Compatible to angled contact APC, ASC, DIN47256/4108	
Power		
Max. Output [3] [6]	typ. > +10 dBm (10 mW)	typ. > +13 dBm (20 mW)
CW Stability (15min) [5]	typ. ± 0.005 dB	typ. ± 0.003 dB
CW Stability (24 h) [4] [5]	typ. ± 0.03 dB	typ. ± 0.01 dB
Side Mode Suppression Ratio (SMSR) [6]	typ. 45 dB	typ. 50 dB
Polarization Extinction Ratio (PER)	typ. > 20 dB	typ. > 20 dB
Dimensions (H x W x D)	75 mm H x 32 mm W x 335 mm D (2.8" x 1.3" x 13.2")	
Weight	0.5 kg	
Recalibration Period	1 year	
Operating Temperature	15°C to 35°C	
Warm-up time [4]	60 min [4]	

	Agilent 81662A	Agilent 81663A
	For Peak Wavelengths see options	
<p>[1] ITU-grid wavelength is shown on display by default, "ITU Channel Options" on page 24 details the peak wavelength that corresponds to each module's option number.</p> <p>[2] Via GPIB tuning resolution < 10pm</p> <p>[3] Class 3A according to IEC 60825-1 (1998) and Class IIIb according to FDA CFR 21(1995)</p> <p>[4] If previously stored at the same temperature 20 min.</p> <p>[5] Controlled environment $\Delta T = \pm 1^{\circ}\text{C}$</p> <p>[6] At maximum power setting and default wavelength.</p> <p>[7] Connector interface not included.</p>		

Supplementary Performance Characteristics

Internal digital modulation mode: Free selection 200 Hz to 100 kHz.
All output signals are pulse shaped, duty cycle 50%.

Internal variable coherence control for linewidth broadening.

ON-switching with fast output power stabilization <20 s.

Output power "attenuation" at default wavelength 6 dB in steps of 0.1 dB.

Tuning speed over full range 30 s.

Polarization maintaining fiber orientation: TE mode in slow axis, in line with connector key.



Performance Tests

The procedures in this section test the optical performance of the instrument. The complete specifications to which the Agilent 81662A and Agilent 81663A DFB Laser Source Modules are tested are given in *“Specifications” on page 25*. All tests can be performed without access to the interior of the instrument. The performance tests refer specifically to tests carried out with APC connectors.

Equipment Required

Equipment required for the performance test is listed below.

Instrument/Accessory	Recommended Model	81662A	81663A	Required Characteristics	Alternative Models
Multimeter Mainframe	Agilent 8163A	x	x		Agilent 8164A, Agilent 8166A
Wavelength Meter	HP 86120C or Burleigh WA-1500	x	x		
Singlemode Fibers	HP 81113PC	x	x		
Connector Interfaces	HP 81000FI HP 81000SI	x x	x x		
x - necessary					

Test Record

Results of the performance test may be noted in the Test Record provided at the end of the Test Procedures. The Test Record can also be used as a permanent record and may be reproduced without written permission from Agilent Technologies.

Test Failure

If the Agilent 81662A, or the Agilent 81663A, DFB Laser Source Module fails any performance test, return the instrument to the nearest Agilent Technologies Sales/Service Office for repair.

Instrument Specification

Specifications are the performance characteristics of the instrument that are certified. These specifications, listed in “*Specifications*” on page 25, are the performance standards or limits against which the Agilent 81662A and Agilent 81663A DFB Laser Source Modules can be tested. The specifications also list some supplemental characteristics of the Agilent 81662A and Agilent 81663A DFB Laser Source Modules. Supplemental characteristics should be considered as additional information.

Any changes in the specifications due to manufacturing changes, design, or traceability to the National Institute of Standards and Technology (NIST), will be covered in a manual change supplement, or revised manual. Such specifications supersede any that were previously published.

Performance Test Instructions

The performance tests given in this section include the Wavelength Repeatability Test and the Wavelength Stability Test. Perform each step in the order given, using the corresponding test equipment.

- NOTE**
- Make sure that all the optical connections used in the the test setups given in the procedures are dry and clean. Refer to the “*Cleaning Information*” on page 45.
 - DO NOT USE INDEX MATCHING OIL.
 - Turn the instruments on, enable the laser and allow the instruments to warm up for at least 60 minutes.
 - The ambient temperature must be constant ($\pm 1\text{K}$) during the tests.

All Wavelength Tests

Make sure that the cable connector, detectors and adapters are clean. Connect the DFB Laser Source Module to the Wavelength Meter as shown in Figure 8.

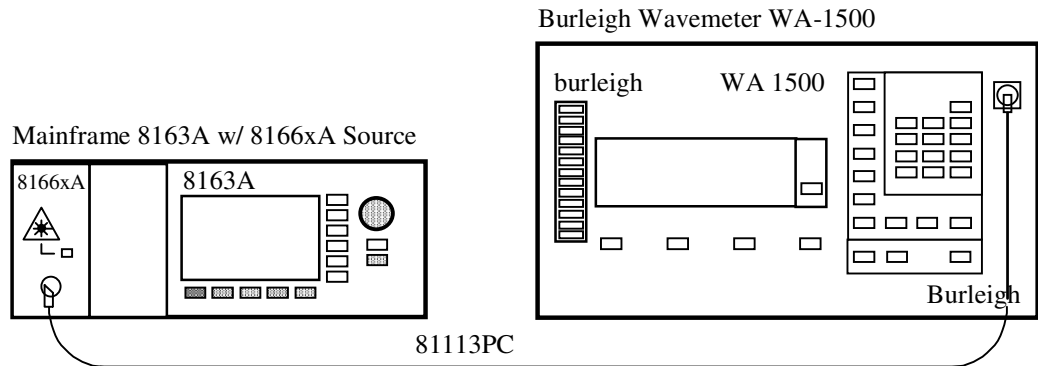

Figure 8 Test Setup for Wavelength Tests

General Settings for Burleigh WA-1500 Wavelength Meter

Set up the Burleigh WA-1500 Wavelength Meter as follows:

- Set *Display* to *Wavelength*
- Set *Medium* to *Vacuum*
- Set *Resolution* to *Auto*
- Set *Averaging* to *On*
- Set *Input Attenuator* to *Auto*.

Wavelength Repeatability Test

- 1** Move to the DFB-Source channel of the Agilent 8163A/4A/6A mainframe and press *Menu*.
- 2** Set the *Wavelength mode* to *Offset* and adjust the *Power* reading to 1mW or 0dBm
- 3** Close the Menu.
- 4** Press the key beside the laser output to switch on the laser output.
- 5** Adjust the frequency offset to the first value given in the test record in column "from wavelength".

- 6** Wait until the wavelength meter has settled. Then measure the wavelength and note the result in the test record as the reference wavelength, "REF".
- 7** Set the frequency offset of the DFB Source module to any value in its range (in the test record, this is given in column "from wavelength").
- 8** Set the frequency offset of the DFB Source back to the reference frequency and wait until the Wavelength Meter has settled.
- 9** Repeat steps 5 to 8 for all frequency offsets given in the test record.
- 10** From all the wavelength measurements, pick the largest measured value and the smallest measured value.
- 11** Calculate the wavelength repeatability by subtracting the largest measured value from the smallest measured value.

Example for 81662A #315

Repeatability of Df = -50 GHz (= reference)	Measurement Results [nm]	Specification
Initial Setting REF =	1531.901	
from -30 GHz to -50 GHz	1531.902	
from -10 GHz to -50 GHz	1531.902	
from 0 GHz to -50 GHz	1531.900	
from +10 GHz to -50 GHz	1531.898	
from +30 GHz to -50 GHz	1531.899	
from +50 GHz to -50 GHz	1531.900	
Largest measured value	1531.902	
Smallest measured Value	1531.898	
Wavelength Repeatability	0.004	<0.06

Wavelength Stability Test

- 1 Move to the DFB-Source channel of the Agilent 8163A Lightwave Multimeter Mainframe and press *Menu*.
- 2 Set the *Wavelength mode* to *Offset* and adjust the *Power* reading to 1mW or 0dBm.
- 3 *Close* the Menu.
- 4 Press $\lambda \rightarrow \lambda_0$
- 5 Press the key beside the laser output to switch on the laser output.
- 6 Every minute for 15 minutes, note the Wavelength Meter reading in the test record.
- 7 From all the wavelength measurements, pick the largest measured value and the smallest measured value.
- 8 Calculate the wavelength stability by subtracting the largest measured value from the smallest measured value.

Example for 81662A #315

Stability of 1531.90 nm	Measurement Results [nm]	Specification
Start value	1531.901	
1 minute	1531.901	
2 minutes	1531.901	
...	...	
15 minutes	1531.898	
Largest measured value	1531.901	
Smallest measured Value	1531.898	
Wavelength Stability	0.003	<0.006

Performance Test for the Agilent 8166_A

Test Equipment Used

Page 2 of 4

	Description	Model No.	Trace No	Cal. Due Date			
1a1	Lightwave Multimeter	Agilent 8163A	_____	_____			
1b	Multichannel System	Agilent 8166A	_____	_____			
1c	Measurement System	Agilent 8164A	_____	_____			
2a	Burleigh Wavelength Meter	WA-1500	_____	_____			
2b	Wavelength Meter	86120C	_____	_____			
3	_____	_____	_____	_____			
4	_____	_____	_____	_____			
5	_____	_____	_____	_____			
6	_____	_____	_____	_____			
7	_____	_____	_____	_____			
8	_____	_____	_____	_____			
9	_____	_____	_____	_____			
10	_____	_____	_____	_____			
11	_____	_____	_____	_____			
12	_____	_____	_____	_____			
Accessories		#	Product	#	Product	#	Product
	Singemode Fibers	1	81113PC	1			
	Connector Interfaces	1	81000FI	1	81000SI		

Performance Test for the Agilent 8166_A

Page 3 of 4

Test Number	Test Description	Minimum Specification.	Result	Maximum Specification.	Measurement Uncertainty
1	Wavelength Repeatability		nm	nm	
	measured at _____ nm (-50 GHz offset frequency)		_____	< (1)	
	measured at _____ nm (0 GHz offset frequency)		_____	< (1)	
	measured at _____ nm (+50 GHz offset frequency)		_____	< (1)	
2	Wavelength Stability, 15min		nm	nm	
	measured at _____ nm (0 GHz offset frequency)		_____	< (1)	
(1): 0.006 nm for 81662A or 0.01 nm for 81663A					

Test Records

Repeatability of $\Delta f = -50$ GHz (= reference)	Measurement Result	Repeatability of $\Delta f = 0$ GHz (= reference)	Measurement Result
Initial Setting REF =	nm	Initial Setting REF =	nm
from -30 GHz to -50 GHz	nm	from -30 GHz to -50 GHz	nm
from -10 GHz to -50 GHz	nm	from -10 GHz to -50 GHz	nm
from 0 GHz to -50 GHz	nm	from 0 GHz to -50 GHz	nm
from +10 GHz to -50 GHz	nm	from +10 GHz to -50 GHz	nm
from +30 GHz to -50 GHz	nm	from +30 GHz to -50 GHz	nm
from +50 GHz to -50 GHz	nm	from +50 GHz to -50 GHz	nm
largest measured value	nm	largest measured value	nm
smallest measured value	nm	smallest measured value	nm
Wavelength Repeatability	nm	Wavelength Repeatability	nm

Performance Test for the Agilent 8166_A

Page 4 of 4

Repeatability of $\Delta f = +50$ GHz (= reference)	Measurement Result
Initial Setting REF =	nm
from -30 GHz to -50 GHz	nm
from -10 GHz to -50 GHz	nm
from 0 GHz to -50 GHz	nm
from +10 GHz to -50 GHz	nm
from +30 GHz to -50 GHz	nm
from +50 GHz to -50 GHz	nm
largest measured value	nm
smallest measured value	nm
Wavelength Repeatability	nm

Stability of _____ nm	Measurement Result [nm]
Start Value	
1.	
2.	
3.	
4.	
5.	
6.	
7.	
8.	
9.	
10.	
11.	
12.	
13.	
14.	
15.	
largest measured value	
smallest measured value	
Wavelength Repeatability	

Cleaning Information

The following Cleaning Information contains some general safety precautions, which must be observed during all phases of cleaning. Consult your specific optical device manuals or guides for full information on safety matters.

Please try, whenever possible, to use physically contacting connectors, and dry connections. Clean the connectors, interfaces, and bushings carefully after use.

If you are unsure of the correct cleaning procedure for your optical device, we recommend that you first try cleaning a dummy or test device.

Agilent Technologies assume no liability for the customer's failure to comply with these requirements.

Cleaning Instructions for this Instrument

This Cleaning Information applies to a number of different types of Optical Equipment.

"How to clean instruments with a physical contact interface" on page 59 is particularly relevant to this module.

Safety Precautions

Please follow the following safety rules:

- Do not remove instrument covers when operating.
- Ensure that the instrument is switched off throughout the cleaning procedures.
- Use of controls or adjustments or performance of procedures other than those specified may result in hazardous radiation exposure.
- Make sure that you disable all sources when you are cleaning any optical interfaces.
- Under no circumstances look into the end of an optical device attached to optical outputs when the device is operational. The laser radiation is not visible to the human eye, but it can seriously damage your eyesight.
- To prevent electrical shock, disconnect the instrument from the mains before cleaning. Use a dry cloth, or one slightly dampened with water, to clean the external case parts. Do not attempt to clean internally.
- Do not install parts or perform any unauthorized modification to optical devices.
- Refer servicing only to qualified and authorized personnel.

Why is it important to clean optical devices?

In transmission links optical fiber cores are about 9 μm (0.00035") in diameter. Dust and other particles, however, can range from tenths to hundredths of microns in diameter. Their comparative size means that they can cover a part of the end of a fiber core, and as a result will reduce the performance of your system.

Furthermore, the power density may burn dust into the fiber and cause additional damage (for example, 0 dBm optical power in a single mode fiber causes a power density of approximately 16 million W/m²). If this happens, measurements become inaccurate and non-repeatable.

Cleaning is, therefore, an essential yet difficult task. Unfortunately, when comparing most published cleaning recommendations, you will discover that they contain several inconsistencies. In this section, we want to suggest ways to help you clean your various optical devices, and thus significantly improve the accuracy and repeatability of your lightwave measurements.

What do I need for proper cleaning?

Some Standard Cleaning Equipment is necessary for cleaning your instrument. For certain cleaning procedures, you may also require certain Additional Cleaning Equipment.

Standard Cleaning Equipment

Before you can start your cleaning procedure you need the following standard equipment:

- Dust and shutter caps
- Isopropyl alcohol
- Cotton swabs
- Soft tissues
- Pipe cleaner
- Compressed air

Dust and shutter caps

All of Agilent Technologies' lightwave instruments are delivered with either laser shutter caps or dust caps on the lightwave adapter. Any cables come with covers to protect the cable ends from damage or contamination.

We suggest these protective coverings should be kept on the equipment at all times, except when your optical device is in use. Be careful when replacing dust caps after use. Do not press the bottom of the cap onto the fiber too hard, as any dust in the cap can scratch or pollute your fiber surface.

If you need further dust caps, please contact your nearest Agilent Technologies sales office.

Isopropyl alcohol

This solvent is usually available from any local pharmaceutical supplier or chemist's shop.

If you use isopropyl alcohol to clean your optical device, do not immediately dry the surface with compressed air (except when you are cleaning very sensitive optical devices). This is because the dust and the dirt is solved and will leave behind filmy deposits after the alcohol is evaporated. You should therefore first remove the alcohol and the dust with a soft tissue, and then use compressed air to blow away any remaining filaments.

If possible avoid using denatured alcohol containing additives. Instead, apply alcohol used for medical purposes.

Never drink this alcohol, as it may seriously damage to your health.

Do not use any other solvents, as some may damage plastic materials and claddings. Acetone, for example, will dissolve the epoxy used with fiber optic connectors. To avoid damage, only use isopropyl alcohol.

Cotton swabs

We recommend that you use swabs such as Q-tips or other cotton swabs normally available from local distributors of medical and hygiene products (for example, a supermarket or a chemist's shop). You may be able to obtain various sizes of swab. If this is the case, select the smallest size for your smallest devices.

Ensure that you use natural cotton swabs. Foam swabs will often leave behind filmy deposits after cleaning.

Use care when cleaning, and avoid pressing too hard onto your optical device with the swab. Too much pressure may scratch the surface, and could cause your device to become misaligned. It is advisable to rub gently over the surface using only a small circular movement.

Swabs should be used straight out of the packet, and never used twice. This is because dust and dirt in the atmosphere, or from a first cleaning, may collect on your swab and scratch the surface of your optical device.

Soft tissues

These are available from most stores and distributors of medical and hygiene products such as supermarkets or chemists' shops.

We recommend that you do not use normal cotton tissues, but multi-layered soft tissues made from non-recycled cellulose. Cellulose tissues are very absorbent and softer. Consequently, they will not scratch the surface of your device over time.

Use care when cleaning, and avoid pressing on your optical device with the tissue. Pressing too hard may lead to scratches on the surface or misalignment of your device. Just rub gently over the surface using a small circular movement.

Use only clean, fresh soft tissues and never apply them twice. Any dust and dirt from the air which collects on your tissue, or which has gathered after initial cleaning, may scratch and pollute your optical device.

Pipe cleaner

Pipe cleaners can be purchased from tobacconists, and come in various shapes and sizes. The most suitable one to select for cleaning purposes has soft bristles, which will not produce scratches.

There are many different kinds of pipe cleaner available from tobacconists.

The best way to use a pipe cleaner is to push it in and out of the device opening (for example, when cleaning an interface). While you are cleaning, you should slowly rotate the pipe cleaner.

Only use pipe cleaners on connector interfaces or on feed through adapters. Do not use them on optical head adapters, as the center of a pipe cleaner is hard metal and can damage the bottom of the adapter.

Your pipe cleaner should be new when you use it. If it has collected any dust or dirt, this can scratch or contaminate your device.

The tip and center of the pipe cleaner are made of metal. Avoid accidentally pressing these metal parts against the inside of the device, as this can cause scratches.

Compressed air

Compressed air can be purchased from any laboratory supplier.

It is essential that your compressed air is free of dust, water and oil. Only use clean, dry air. If not, this can lead to filmy deposits or scratches on the surface of your connector. This will reduce the performance of your transmission system.

When spraying compressed air, hold the can upright. If the can is held at a slant, propellant could escape and dirty your optical device. First spray into the air, as the initial stream of compressed air could contain some condensation or propellant. Such condensation leaves behind a filmy deposit.

Please be friendly to your environment and use a CFC-free aerosol.

Additional Cleaning Equipment

Some Cleaning Procedures need the following equipment, which is not required to clean each instrument:

- Microscope with a magnification range about 50X up to 300X
- Ultrasonic bath
- Warm water and liquid soap
- Premoistened cleaning wipes
- Polymer film
- Infrared Sensor Card

Microscope with a magnification range about 50X up to 300X

A microscope can be found in most photography stores, or can be obtained through or specialist mail order companies. Special fiber-scopes are available from suppliers of splicing equipment.

Ideally, the light source on your microscope should be very flexible. This will allow you to examine your device closely and from different angles.

A microscope helps you to estimate the type and degree of dirt on your device. You can use a microscope to choose an appropriate cleaning method, and then to examine the results. You can also use your microscope to judge whether your optical device (such as a connector) is severely scratched and is, therefore, causing inaccurate measurements.

Ultrasonic bath

Ultrasonic baths are also available from photography or laboratory suppliers or specialist mail order companies.

An ultrasonic bath will gently remove fat and other stubborn dirt from your optical devices. This helps increase the life span of the optical devices.

Only use isopropyl alcohol in your ultrasonic bath, as other solvents may cause damage.

Warm water and liquid soap

Only use water if you are sure that there is no other way of cleaning your optical device without causing corrosion or damage. Do not use hot water, as this may cause mechanical stress, which can damage your optical device.

Ensure that your liquid soap has no abrasive properties or perfume in it. You should also avoid normal washing up liquid, as it can cover your device in an iridescent film after it has been air dried.

Some lenses and mirrors also have a special coating, which may be sensitive to mechanical stress, or to fat and liquids. For this reason we recommend you do not touch them.

If you are not sure how sensitive your device is to cleaning, please contact the manufacturer or your sales distributor.

Premoistened cleaning wipes

Use pre-moistened cleaning wipes as described in each individual cleaning procedure. Cleaning wipes may be used in every instance where a moistened soft tissue or cotton swab is applied.

Polymer film

Polymer film is available from laboratory suppliers or specialist mail order companies.

Using polymer film is a gentle method of cleaning extremely sensitive devices, such as reference reflectors and mirrors.

Infrared Sensor Card

Infrared sensor cards are available from laboratory suppliers or specialist mail order companies.

With this card you are able to control the shape of laser light emitted. The invisible laser beam is projected onto the sensor card, then becomes visible to the normal eye as a round spot.

Take care never to look into the end of a fiber or any other optical component, when they are in use. This is because the laser can seriously damage your eyes.

Preserving Connectors

Listed below are some hints on how best to keep your connectors in the best possible condition.

Making Connections Before you make any connection you must ensure that all cables and connectors are clean. If they are dirty, use the appropriate cleaning procedure.

When inserting the ferrule of a patchcord into a connector or an adapter, make sure that the fiber end does not touch the outside of the mating connector or adapter. Otherwise you will rub the fiber end against an unsuitable surface, producing scratches and dirt deposits on the surface of your fiber.

Dust Caps and Shutter Caps Be careful when replacing dust caps after use. Do not press the bottom of the cap onto the fiber as any dust in the cap can scratch or dirty your fiber surface.

When you have finished cleaning, put the dust cap back on, or close the shutter cap if the equipment is not going to be used immediately.

Always keep the caps on the equipment when it is not in use.

All of Agilent Technologies' lightwave instruments and accessories are shipped with either laser shutter caps or dust caps. If you need additional or replacement dust caps, contact your nearest Agilent Technologies Sales/Service Office.

Immersion Oil and Other Index Matching Compounds Wherever possible, do not use immersion oil or other index matching compounds with your device. They are liable to impair and dirty the surface of the device. In addition, the characteristics of your device can be changed and your measurement results affected.

Cleaning Instrument Housings

Use a dry and very soft cotton tissue to clean the instrument housing and the keypad. Do not open the instruments as there is a danger of electric shock, or electrostatic discharge. Opening the instrument can cause damage to sensitive components, and in addition your warranty will be voided.

Which Cleaning Procedure should I use ?

- Light dirt** If you just want to clean away light dirt, observe the following procedure for all devices:
- Use compressed air to blow away large particles.
 - Clean the device with a dry cotton swab.
 - Use compressed air to blow away any remaining filament left by the swab.

Heavy dirt If the above procedure is not enough to clean your instrument, follow one of the procedures below. Please consult *“Cleaning Instructions for this Instrument” on page 46* for the procedure relevant for this instrument.

If you are unsure of how sensitive your device is to cleaning, please contact the manufacturer or your sales distributor

How to clean connectors

Cleaning connectors is difficult as the core diameter of a single-mode fiber is only about 9 μm . This generally means you cannot see streaks or scratches on the surface. To be certain of the condition of the surface of your connector and to check it after cleaning, you need a microscope.

In the case of scratches, or of dust that has been burnt onto the surface of the connector, you may have no option but to polish the connector. This depends on the degree of dirtiness, or the depth of the scratches. This is a difficult procedure and should only be performed by a skilled person, and as a last resort as it wears out your connector.

WARNING

Never look into the end of an optical cable that is connected to an active source.

To assess the projection of the emitted light beam you can use an infrared sensor card. Hold the card approximately 5 cm from the output of the connector. The invisible emitted light is projected onto the card and becomes visible as a small circular spot.

Preferred Procedure Use the following procedure on most occasions.

- 1 Clean the connector by rubbing a new, dry cotton swab over the surface using a small circular movement.
- 2 Blow away any remaining lint with compressed air.

Procedure for Stubborn Dirt Use this procedure when there is greasy dirt on the connector:

- 1 Moisten a new cotton swab with isopropyl alcohol.
- 2 Clean the connector by rubbing the cotton swab over the surface using a small circular movement.
- 3 Take a new, dry soft tissue and remove the alcohol, dissolved sediment and dust, by rubbing gently over the surface using a small circular movement.
- 4 Blow away any remaining lint with compressed air.

An Alternative Procedure A better, more gentle, but more expensive cleaning procedure is to use an ultrasonic bath with isopropyl alcohol.

- 1 Hold the tip of the connector in the bath for at least three minutes.
- 2 Take a new, dry soft tissue and remove the alcohol, dissolved sediment and dust, by rubbing gently over the surface using a small circular movement.
- 3 Blow away any remaining lint with compressed air.

How to clean connector adapters

CAUTION

Some adapters have an anti-reflection coating on the back to reduce back reflection. This coating is extremely sensitive to solvents and mechanical abrasion. Extra care is needed when cleaning these adapters.

Preferred Procedure Use the following procedure on most occasions.

- 1 Clean the adapter by rubbing a new, dry cotton swab over the surface using a small circular movement.
- 2 Blow away any remaining lint with compressed air.

Procedure for Stubborn Dirt Use this procedure when there is greasy dirt on the adapter:

- 1 Moisten a new cotton swab with isopropyl alcohol.
- 2 Clean the adapter by rubbing the cotton swab over the surface using a small circular movement.
- 3 Take a new, dry soft tissue and remove the alcohol, dissolved sediment and dust, by rubbing gently over the surface using a small circular movement.
- 4 Blow away any remaining lint with compressed air.

How to clean connector interfaces

CAUTION

Be careful when using pipe cleaners, as the core and the bristles of the pipe cleaner are hard and can damage the interface.

Do not use pipe cleaners on optical head adapters, as the hard core of normal pipe cleaners can damage the bottom of an adapter.

Preferred Procedure Use the following procedure on most occasions.

- 1 Clean the interface by pushing and pulling a new, dry pipe cleaner into the opening. Rotate the pipe cleaner slowly as you do this.
- 2 Then clean the interface by rubbing a new, dry cotton swab over the surface using a small circular movement.
- 3 Blow away any remaining lint with compressed air.

Procedure for Stubborn Dirt Use this procedure when there is greasy dirt on the interface:

- 1 Moisten a new pipe cleaner with isopropyl alcohol.
- 2 Clean the interface by pushing and pulling the pipe cleaner into the opening. Rotate the pipe cleaner slowly as you do this.

- 3 Moisten a new cotton swab with isopropyl alcohol.
- 4 Clean the interface by rubbing the cotton swab over the surface using a small circular movement.
- 5 Using a new, dry pipe cleaner, and a new, dry cotton swab remove the alcohol, any dissolved sediment and dust.
- 6 Blow away any remaining lint with compressed air.

How to clean bare fiber adapters

Bare fiber adapters are difficult to clean. Protect from dust unless they are in use.

CAUTION

Never use any kind of solvent when cleaning a bare fiber adapter as solvents can:

- Damage the foam inside some adapters.
- Deposit dissolved dirt in the groove, which can then dirty the surface of an inserted fiber.

Preferred Procedure Use the following procedure on most occasions.

- 1 Blow away any dust or dirt with compressed air.

Procedure for Stubborn Dirt Use this procedure when there is greasy dirt on the adapter:

- 1 Clean the adapter by pushing and pulling a new, dry pipe cleaner into the opening. Rotate the pipe cleaner slowly as you do this.

CAUTION

Be careful when using pipe cleaners, as the core and the bristles of the pipe cleaner are hard and can damage the adapter.

- 2 Clean the adapter by rubbing a new, dry cotton swab over the surface using a small circular movement.
- 3 Blow away any remaining lint with compressed air.

How to clean lenses

Some lenses have special coatings that are sensitive to solvents, grease, liquid and mechanical abrasion. Take extra care when cleaning lenses with these coatings.

Lens assemblies consisting of several lenses are not normally sealed. Therefore, use as little alcohol as possible, as it can get between the lenses and in doing so can change the properties of projection.

Preferred Procedure Use the following procedure on most occasions.

- 1 Clean the lens by rubbing a new, dry cotton swab over the surface using a small circular movement.
- 2 Blow away any remaining lint with compressed air.

Procedure for Stubborn Dirt Use this procedure when there is greasy dirt on the lens:

- 1 Moisten a new cotton swab with isopropyl alcohol.
- 2 Clean the lens by rubbing the cotton swab over the surface using a small circular movement.
- 3 Using a new, dry cotton swab remove the alcohol, any dissolved sediment and dust.
- 4 Blow away any remaining lint with compressed air.

How to clean instruments with a fixed connector interface

You should only clean instruments with a fixed connector interface when it is absolutely necessary. This is because it is difficult to remove any used alcohol or filaments from the input of the optical block.

It is important, therefore, to keep dust caps on the equipment at all times, except when your optical device is in use.

If you do discover filaments or particles, the only way to clean a fixed connector interface and the input of the optical block is to use compressed air.

If there are fluids or fat in the connector, please refer the instrument to the skilled personnel of Agilent's service team.

CAUTION

Only use clean, dry compressed air. Make sure that the air is free of dust, water, and oil. If the air that you use is not clean and dry, this can lead to filmy deposits or scratches on the surface of your connector interface. This will degrade the performance of your transmission system.

Never try to open the instrument and clean the optical block by yourself, because it is easy to scratch optical components, and cause them to become misaligned.

How to clean instruments with an optical glass plate

Some instruments, for example, the optical heads from Agilent Technologies have an optical glass plate to protect the sensor. Clean this glass plate in the same way as optical lenses (see *"How to clean lenses"* on page 58).

How to clean instruments with a physical contact interface

Remove any connector interfaces from the optical output of the instrument before you begin the cleaning procedure.

Cleaning interfaces is difficult as the core diameter of a single-mode fiber is only about 9 μm . This generally means you cannot see streaks or scratches on the surface. To be certain of the degree of pollution on the surface of your interface and to check whether it has been removed after cleaning, you need a microscope.

WARNING

Never look into an optical output, because this can seriously damage your eyesight.

To assess the projection of the emitted light beam you can use an infrared sensor card. Hold the card approximately 5 cm from the interface. The invisible emitted light is projected onto the card and becomes visible as a small circular spot.

Preferred Procedure Use the following procedure on most occasions.

- 1 Clean the interface by rubbing a new, dry cotton swab over the surface using a small circular movement.
- 2 Blow away any remaining lint with compressed air.

Procedure for Stubborn Dirt Use this procedure when there is greasy dirt on the interface:

- 1 Moisten a new cotton swab with isopropyl alcohol.
- 2 Clean the interface by rubbing the cotton swab over the surface using a small circular movement.
- 3 Take a new, dry soft tissue and remove the alcohol, dissolved sediment and dust, by rubbing gently over the surface using a small circular movement.
- 4 Blow away any remaining lint with compressed air.

How to clean instruments with a recessed lens interface

WARNING

For instruments with a deeply recessed lens interface (for example the Agilent 81633A and 81634A Power Sensors) do NOT follow this procedure. Alcohol and compressed air could damage your lens even further.

Keep your dust and shutter caps on when your instrument is not in use. This should prevent it from getting too dirty. If you must clean such instruments, please refer the instrument to the skilled personnel of Agilent's service team.

Preferred Procedure Use the following procedure on most occasions.

- 1 Blow away any dust or dirt with compressed air.
If this is not sufficient, then
- 2 Clean the interface by rubbing a new, dry cotton swab over the surface using a small circular movement.
- 3 Blow away any remaining lint with compressed air.

Procedure for Stubborn Dirt Use this procedure when there is greasy dirt on the interface, and using the preferred procedure is not sufficient. Using isopropyl alcohol should be your last choice for recessed lens interfaces because of the difficulty of cleaning out any dirt that is washed to the edge of the interface:

- 1 Moisten a new cotton swab with isopropyl alcohol.
- 2 Clean the interface by rubbing the cotton swab over the surface using a small circular movement.
- 3 Take a new, dry soft tissue and remove the alcohol, dissolved sediment and dust, by rubbing gently over the surface using a small circular movement.
- 4 Blow away any remaining lint with compressed air.

How to clean optical devices which are sensitive to mechanical stress and pressure

Some optical devices, such as the Agilent 81000BR Reference Reflector, which has a gold plated surface, are very sensitive to mechanical stress or pressure. Do not use cotton swabs, soft tissues or other mechanical cleaning tools, as these can scratch or destroy the surface.

Preferred Procedure Use the following procedure on most occasions.

- 1 Blow away any dust or dirt with compressed air.

Procedure for Stubborn Dirt To clean devices that are extremely sensitive to mechanical stress or pressure you can also use an optical clean polymer film. This

procedure is time-consuming, but you avoid scratching or destroying the surface.

- 1 Put the film on the surface and wait at least 30 minutes to make sure that the film has had enough time to dry.
- 2 Remove the film and any dirt with special adhesive tapes.

Alternative Procedure For these types of optical devices you can often use an ultrasonic bath with isopropyl alcohol. Only use the ultrasonic bath if you are sure that it won't cause any damage any part of the device.

- 1 Put the device into the bath for at least three minutes.
- 2 Blow away any remaining liquid with compressed air.

If there are any streaks or drying stains on the surface, repeat the cleaning procedure.

How to clean metal filters or attenuator gratings

This kind of device is extremely fragile. A misalignment of the grating leads to inaccurate measurements. Never touch the surface of the metal filter or attenuator grating. Be very careful when using or cleaning these devices. Do not use cotton swabs or soft tissues, as there is the danger that you cannot remove the lint and that the device will be destroyed by becoming mechanically distorted.

Preferred Procedure Use the following procedure on most occasions.

- 1 Use compressed air at a distance and with low pressure to remove any dust or lint.

Procedure for Stubborn Dirt Do not use an ultrasonic bath as this can damage your device.

Use this procedure when there is greasy dirt on the device:

- 1 Put the optical device into a bath of isopropyl alcohol, and wait at least 10 minutes.
- 2 Remove the fluid using compressed air at some distance and with low pressure. If there are any streaks or drying stains on the surface, repeat the whole cleaning procedure.

Additional Cleaning Information

The following cleaning procedures may be used with other optical equipment:

- How to clean bare fiber ends
- How to clean large area lenses and mirrors

How to clean bare fiber ends

Bare fiber ends are often used for splices or, together with other optical components, to create a parallel beam. The end of a fiber can often be scratched. You make a new cleave. To do this:

- 1 Strip off the cladding.
- 2 Take a new soft tissue and moisten it with isopropyl alcohol.
- 3 Carefully clean the bare fiber with this tissue.
- 4 Make your cleave and immediately insert the fiber into your bare fiber adapter in order to protect the surface from dirt.

How to clean large area lenses and mirrors

Some mirrors, as those from a monochromator, are very soft and sensitive. Therefore, never touch them and do not use cleaning tools such as compressed air or polymer film.

Some lenses have special coatings that are sensitive to solvents, grease, liquid and mechanical abrasion. Take extra care when cleaning lenses with these coatings.

Lens assemblies consisting of several lenses are not normally sealed. Therefore, use as little liquid as possible, as it can get between the lenses and in doing so can change the properties of projection.

Preferred Procedure Use the following procedure on most occasions.

- 1 Blow away any dust or dirt with compressed air.

Procedure for Stubborn Dirt Use this procedure when there is greasy dirt on the lens:

CAUTION

Only use water if you are sure that there is no other way of cleaning your optical device without causing corrosion or damage.

Only use water if you are sure that there is no other way of cleaning your optical device without causing corrosion or damage. Do not use hot water, as this may cause mechanical stress, which can damage your optical device.

Ensure that your liquid soap has no abrasive properties or perfume in it. You should also avoid normal washing up liquid, as it can cover your device in an iridescent film after it has been air dried.

Some lenses and mirrors also have a special coating, which may be sensitive to mechanical stress, or to fat and liquids. For this reason we recommend you do not touch them.

If you are not sure how sensitive your device is to cleaning, please contact the manufacturer or your sales distributor.

- 1 Moisten the lens or the mirror with water.
- 2 Put a little liquid soap on the surface and gently spread the liquid over the whole area.
- 3 Wash off the emulsion with water, being careful to remove it all, as any remaining streaks can impair measurement accuracy.
- 4 Take a new, dry soft tissue and remove the water, by rubbing gently over the surface using a small circular movement.
- 5 Blow away remaining lint with compressed air.

Alternative Procedure A To clean lenses that are extremely sensitive to mechanical stress or pressure you can also use an optical clean polymer film. This procedure is time-consuming, but you avoid scratching or destroying the surface.

- 1 Put the film on the surface and wait at least 30 minutes to make sure that the film has had enough time to dry.
- 2 Remove the film and any dirt with special adhesive tapes.

Alternative Procedure B If your lens is sensitive to water then:

- 1 Moisten the lens or the mirror with isopropyl alcohol.
- 2 Take a new, dry soft tissue and remove the alcohol, dissolved sediment and dust, by rubbing gently over the surface using a small circular movement.
- 3 Blow away remaining lint with compressed air.

Other Cleaning Hints

Selecting the correct cleaning method is an important element in maintaining your equipment and saving you time and money. This Appendix highlights the main cleaning methods, but cannot address every individual circumstance.

This section contains some additional hints which we hope will help you further. For further information, please contact your local Agilent Technologies representative.

Making the connection Before you make any connection you must ensure that all lightwave cables and connectors are clean. If not, then use the appropriate cleaning methods.

When you insert the ferrule of a patchcord into a connector or an adapter, ensure that the fiber end does not touch the outside of the mating connector or adapter. Otherwise, the fiber end will rub up against something which could scratch it and leave deposits.

Lens cleaning papers Some special lens cleaning papers are not suitable for cleaning optical devices like connectors, interfaces, lenses, mirrors and so on. To be absolutely certain that a cleaning paper is applicable, please ask the salesperson or the manufacturer.

Immersion oil and other index matching compounds Do not use immersion oil or other index matching compounds with optical sensors equipped with recessed lenses. They are liable to dirty the detector and impair its performance. They may also alter the property of depiction of your optical device, thus rendering your measurements inaccurate.

Cleaning the housing and the mainframe When cleaning either the mainframe or the housing of your instrument, only use a dry and very soft cotton tissue on the surfaces and the numeric pad.

Never open the instruments as they can be damaged. Opening the instruments puts you in danger of receiving an electrical shock from your device, and renders your warranty void.

Index

A

Accessories 19

C

Connectors

 angled contact 16

 straight contact 16

G

Getting Started 13

 Enable/Disable Laser Output 15

 Front Panel 15

 What is a DFB Laser Source Module? 15

I

Initial Safety Information 5

ITU Channel Options 22

O

Optical Output 16

P

Performance Tests 33

 Agilent 8166_A 41

 All Wavelength Tests 37

 Equipment Required 35

 Instructions 36

 Test Failure 35

 Test Record 35

 Wavelength Repeatability 37

 Wavelength Stability 39

Polarization Maintaining Fiber 16

R

Recommended Connector Interfaces 21

S

Safety

 information for laser source 5

Specifications 25

 DFB Source Module 31

Supplementary Performance

Characteristics 32

W

Wavelength Accuracy Below Maximum

Power 17



www.agilent.com

© Agilent Technologies GmbH 2000 - 2002

Printed in Germany February 20, 2002



81661-90A15

Artisan Technology Group is an independent supplier of quality pre-owned equipment

Gold-standard solutions

Extend the life of your critical industrial, commercial, and military systems with our superior service and support.

We buy equipment

Planning to upgrade your current equipment? Have surplus equipment taking up shelf space? We'll give it a new home.

Learn more!

Visit us at artisanng.com for more info on price quotes, drivers, technical specifications, manuals, and documentation.

Artisan Scientific Corporation dba Artisan Technology Group is not an affiliate, representative, or authorized distributor for any manufacturer listed herein.

We're here to make your life easier. How can we help you today?

(217) 352-9330 | sales@artisanng.com | artisanng.com

